

Tenditore da incasso tipo TN101 - TN103 Recessed wardrobe adjusters TN101 - TN103 type

NORMALMENTE ASSEMBLATI SU PANNELLI DI LEGNO O AGGLOMERATI E TAMBURATI. FISSAGGIO CON VITI. SPESSORE MINIMO 16. INTERASSE MIN 1200 MAX 2800

NORMALLY ASSEMBLED ON WOODEN PANELS OR AGGLOMERATES AND HOLLOW WOOD PANELS. FIXING WITH SCREWS. MINIMUM THICKNESS 16. CENTRE DISTANCE: MINIMUM 1200 MAXIMUM 2800

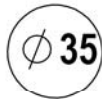

acciaio - zama - PVC grigio
steel - die-cast - grey PVC

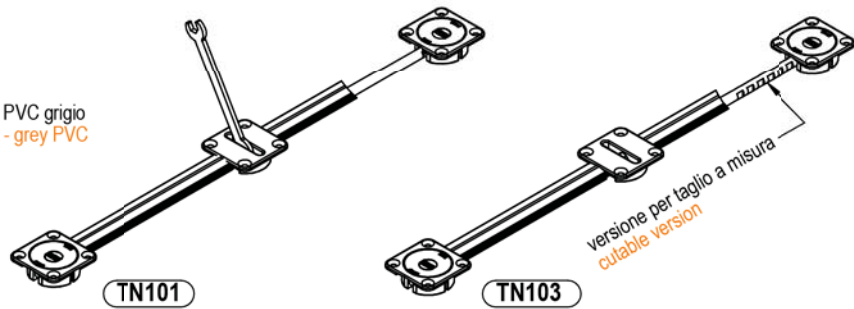

6 Nm



60 N

test agglomerato 2500x400x20
panel test 2500x400x20

6 Nm



75 N

test agglomerato 2500x400x28
panel test 2500x400x28

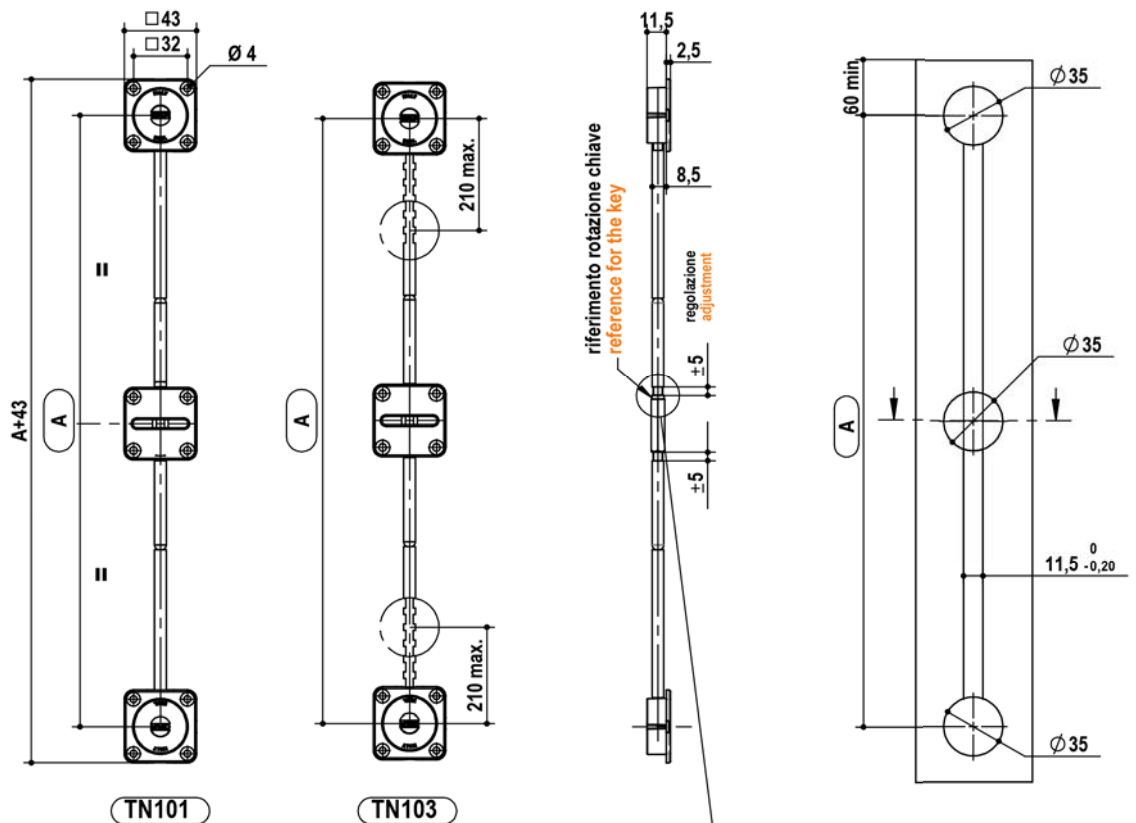

tipo type	misura measure	A	finitura finishing	box	kg / box
TN101.	1728.	1728	07 nichelato nickel	25	19,2
	1988.	1988			21,6
	2248.	2248			24
	2329.	2329			24,8
	2598.	2598			27,1

tipo type	misura measure	A	finitura finishing	box	kg / box
TN103.	2248.	2248	07 nichelato nickel	25	24
	2598.	2598			27,1

es./e.g.: TN101.2248.07

QUANDO SI ASSEMBLA PIU' DI UN TENDITORE E' IMPORTANTE TENERE IL RIFERIMENTO DELLA ROTAZIONE DELLA CHIAVE DALLO STESSO LATO.
WHEN ASSEMBLING MORE THAN ONE TENSIONER, IT IS IMPORTANT TO KEEP THE KEY ROTATION REFERENCE ON THE SAME SIDE.